



# MEBLEVA B.V.

YOUR RESPONSIBLE SUPPLIER OF WOODEN PRODUCTS



## VISION

To become one of the largest suppliers of the furniture and its component parts in Europe.

## MISSION

To create and facilitate the production of wooden products that are distinguished by their high quality and affordable price, enclosing our soul, valuable experience, high-efficient technologies and responsible attitude to the environment in the manufacturing process.

## OUR ADVANTAGES

### EXPERIENCE

Our factory was established in 1905. Since that time, we have been acquiring valuable experience and elaborate technologies of wood processing.

### OWN FACTORY

Products that we offer are manufactured in a modern factory with the full (closed) cycle of wood processing.

### QUALITY AND PRICE

Thanks to the modern machinery, high-qualified personnel and full cycle of wood processing, we guarantee the high quality and affordable price of our products.

### CSR

As an identifiable player of the woodworking industry in Ukraine, we implement the initiatives to preserve the nature, and develop them day by day.

### WIDE ASSORTMENT

We produce a wide assortment of goods, specifically, from sawn timber to interior doors and from furniture to pellets.

### INDIVIDUAL APPROACH

We are able to realize all your ideas and desires with the help of own and flexible production.

## PRODUCTION



The history of our factory has started in 1905. Since that time, we have been acquiring valuable experience which helps us manufacture the most complicated wooden goods. In addition, the factory is placed in the Northern part of Ukraine - the center of Ukrainian woodlands. Therefore, the raw material supply is constant and reliable.

Our suppliers of round timber are only state forestries. Therefore, we can guarantee the high quality and safety of our goods and responsible attitude to the environment.

The superior quality of our products is provided by the qualified employees, precious technologies, modern machinery and tools for wood processing. The total area of the production premises is 15000m<sup>2</sup>.

As to our machinery, main supplier of the sawmill equipment is Stefan Drozdowski. Drying chambers are equipped with an automatic control system from the Italian company Logica H&S. Moreover, a semiautomatic optimizer Salvador and finger joint line Spanevello, German machinery for veneer processing Kuper and other European machinery, namely, SICAR, OSAMA, QWICKWOOD, VOLPATO, BUTFERING, BARBERAN, etc. The most substantial feature of our production is the closed cycle of wood processing, namely, from harvesting to waste processing.

Due to the flexible and efficient organizational structure, the manufactory produces a wide range of high quality wooden products.



## PRODUCTS



Pellets



Furniture boards



Interior doors



Glulam



Molding



Sawn timber

# MEBLEVA

## SAWN TIMBER



High-quality  
pine used



Flexibility  
of sizes



Humidity  
8-10%



Different qualitative  
parameters available



Optimized  
logistics

We offer sawn timber with different sizes and qualitative parameters.

Primary wood processing takes place in a separate and modern sawmill department. This fact lets us achieve the high capacity, accurate sizes and flexibility of sawn timber manufacturing in order to satisfy our customers' needs. The next and critically important stage of sawn timber production is drying. During this technological process, wood is loaded into drying chambers with an automatic control system from the Italian company Logica H&S, where it is dried to a preset humidity. Finally, the last stage of timber manufacturing is its cutting to a necessary length and packaging.



## GLULAM

In the glulam production, we use only dried sawn timber with 8-10% humidity that decreases the possibility of future deformations during the exploitation to 0.

All the defects of wood, such as knots, splits, resin pockets are cut out on the Italian optimizer Salvador. Then, previously made semi fabrications are transported to a finger joint line Spanevello where they are glued together in glulam of preset length. Accurate geometrical parameters are provided by the surfacing of a base side and further processing on a four-cutter machine. Depending on the needs of a customer, glulam can be glued together side-by-side and formed into different shapes.



**HIGH-QUALITY  
RAW MATERIALS  
USED**



**FLEXIBILITY  
OF SIZES**



**HUMIDITY  
8-10%**



**DIFFERENT QUALITATIVE  
PARAMETERS AVAILABLE**



**OPTIMIZED LOGISTICS**

## FURNITURE BOARDS



**HUMIDITY  
8-10%**



**FLEXIBILITY  
OF SIZES**



**HIGH-QUALITY  
RAW MATERIALS  
USED**



**OPTIMIZED LOGISTICS**



**DIFFERENT QUALITATIVE  
PARAMETERS AVAILABLE**

The technological process of furniture board manufacturing includes a full cycle of glulam production which is additionally glued into boards with preset sizes on a press machine.

After that, boards are processed on an Italian thicknesser to obtain the necessary thickness (deviation is up to 0.3 mm). Depending on the customer's needs, furniture boards can be grinded in order to obtain a perfectly smooth surface. The final stage is the cutting of the furniture board to the required sizes on the panel-sizing machine Sicar with further packaging.



## MOLDING

||| Pine, MDF or oak

 High-quality raw materials used

 Flexibility of sizes and shapes

 Optimized logistics

Our company produces a wide range of molding, shaped goods and furniture parts. Mainly, we use sawn timber, glulam, furniture boards or MDF as raw materials.

Depending on the needs of a customer, such products can be covered by the veneer of natural wood (oak, ash, alder, beech, etc.), colored and lacquered. Manufacturing and processing of veneered goods are done with the help of KUPER (Germany), Barberan (Spain), Sicar (Italy) and Volpato's (Italy) equipment.

The major types of molding and shaped goods are floor board, lining, plinth, door frame and trim, parts of stairs and furniture, etc.

## INTERIOR DOORS

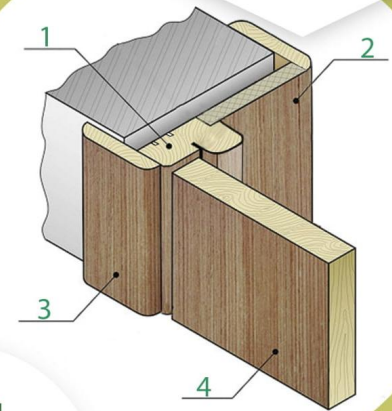

### Molding of the door

- 1 – Door frame
- 2 – Extension panel
- 3 – Door trim
- 4 – Door leaf

 High-quality raw materials used

 Wide assortment

 Sectional construction

 Flexibility of sizes

 Optimized logistics

One of the main types of our products is interior doors. They can be separated into 3 categories, namely: veneered doors, painted MDF doors and pine doors.

All the doors are produced on the modern equipment by using exceptional quality materials and high-efficient technologies. Moreover, our interior doors have the sectional (assembling) construction which makes them more resistant to the influence of external factors during exploitation and the process of damage repairing significantly cheaper and easier.

CATALOG





## PELLETS



Our pellets are well known on the Ukrainian pellets market and have earned a distinctive reputation due to the perfect quality. This fact let us easily find customers of our granulated biofuel in Europe, in particular, Czech Republic, Italy, and Romania.

During the pellets' manufacturing process, we only use our own wood waste that was generated at each stage of the main production. The pellets are produced in a separate department by using Italian granulation line. Moreover, we use debark machines before processing of round timber in order to decrease the content of non-combustible materials in the generated waste during the manufacturing of our products. Therefore, the ash content of our pellets is critically low.

Based on the previously mentioned facts, we guarantee the superior quality of produced biofuel to our customers that is confirmed by the SGS certification center. The pellets can be packed into 15kg plastic bags or 1t bags.



Only premium quality



Produced out of own wood waste



Optimized logistics

### The main characteristics of our pellets:

Diameter	6 mm	Moisture	8,46%
Ash content	0,29%	Bulk density	697,31 kg/m <sup>3</sup>
Sulphur	0,01%	Cross calorific value	4931 kcal/kg

SGS certificate



## CSR



As a recognizable player of the Ukrainian woodworking industry, it is critically important to conduct and follow corporate social responsibility in order to save the environment for the future generations regardless significant costs.

As the manufacturer of different types of wooden products, we perform the following initiatives:

Efficient usage of raw materials (more than 99%) due to the modern equipment and more than a century of experience in woodworking industry;

All round timber is supplied by the state forestries. It guarantees the quality, ecological cleanness and safety of our goods;

The closed cycle of wood processing. All the waste created during the production processes are used to produce the biofuel, in particular , high-quality pellets, facilities heating and timber drying. We stopped using natural gas in 2002;

We always help state forestries to conduct the environmental harvesting in order to keep the forests clean.

We are sure that all the previously listed initiatives are considerable and have only a positive impact on the preservation of nature.





**EMAIL**

office@mebleva.nl



**CALL US !**

+31 61 521 50 50



**POST ADDRESS**

Bijlmerdreef 1166  
1103 JV Amsterdam  
The Netherlands

KvK-nr.: 71086919  
BTW-nr.: NL858574044B01

**mebleva.nl**